

Rear Axle Shaft Kits

- 41 total Part Numbers covering the most failure-prone RWD vehicles
- Over 33 million registered vehicles covered by the Dorman Rear Axle Kit Program

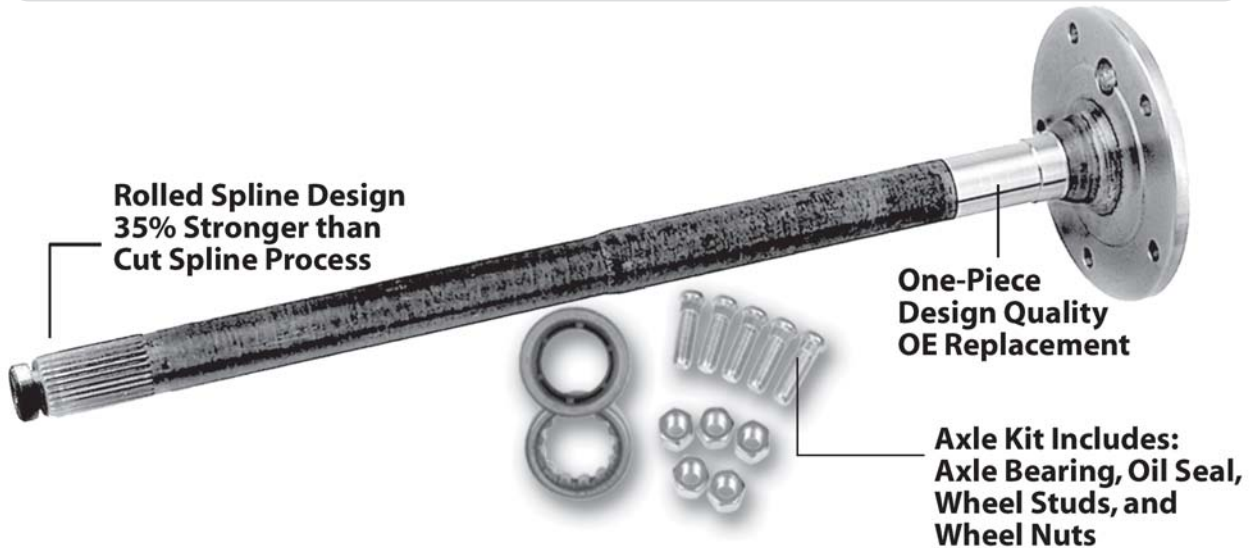

Dorman Rear Axle Shaft Kits – Do the job right!



Common signs to replace your Rear Axle:

- Grinding sound in axle area could mean the bearing has seized to the shaft surface
- Bent Rear Axle – Shakes vehicle when driving
- Unusual tire wear
- Loss of rear wheel drive or power

Always **CHECK** Rear Axle Splines and Axle Shaft for cracks or flat spots when doing Rear Axle overhauls and repairs.

Related Rear Axle Shaft Sales

81048



Differential Shaft Lock Bolt

Fits GM vehicles 1994-90, Ford 2003-80, Ford cars and trucks 2003-80. Retains pinion shaft. Must be removed to perform rear differential work or when replacing rear axle shafts. Bolts break, wear out or are often misplaced.

81050



Axle Shaft Lock (C-Clips)

GM. Replaces lost or damaged rear axle locks. Worn or damaged locks should be replaced to ensure proper axle lock-in. Axle locks should be replaced whenever axle work is performed. Available in two sizes to provide a proper fit.

81053



Pinion Nut

GM 1995-61. Prevailing torque style. 7/8"-14.

Activant Path

*Differential Axle/
Drive Train*

Activant Code

DDA

**Applications begin
on page 433.**

Rear Axle Shafts Kits



	Part #	Length	No. of Holes	Spline	Applications	Orientation
GM						
	630-100	33-5/16"	5	30	1995-88 10 Bolt 8.5" Dia. Ring Gear; GM/GMC Vans 1/2 & 3/4 Ton, RH & LH; 2 Wheel Drive	Left or Right
	630-101	33"	6	30	1999-88 GM 10 Bolt, 8.5" Dia. Ring Gear; Tahoe & Yukon with 4 Wheel Drive; Chevy Blazer/Jimmy/Suburban 4 WD, Chev / GMC Pickups 1500 4x4; Fits 2000 Model OLD Body Style "R" Applications	Left or Right
	630-102	31-5/16"	6	28	1988-78 GM 10 Bolt, 8.5" Dia. Ring Gear; Blazer, Jimmy, Pickups and Suburban 1/2 Ton; 4x4	Left or Right
	630-103	29"	5	28	1997-88 GM 7-5/8" Dia. Ring Gear; S-10 Blazer, Jimmy, Pickups and Sonoma with 4x4	Left or Right
	630-104	31-5/16"	6	30	1991-87 GM 10 Bolt 8.5" Dia. Ring Gear; "R/V" Blazer, Jimmy, Pickups 1/2 Ton with 4x4	Left or Right
	630-105	31-9/32"	6	30	1981-70 GM 12 Bolt, 8-7/8" Dia. Ring Gear; Blazer, Jimmy, Pickups and Suburban 1/2 Ton with 4x4	Left or Right
	630-106	31-13/16"	5	30	1999-88 GM 10 Bolt, 8.5" Dia. Ring Gear; "C" Pickup, Suburban 1/2 Ton, 2 Wheel Drive; GMC Yukon, 2 Wheel Drive; fits 2000 Model Old Body Style Applications	Left or Right
	630-107	31-3/8"	5	30	1991-87 GM 10 Bolt, 8.5" Dia. Ring Gear; Chevy Blazer, Suburban 10/1500 Ser., 2 Wheel Drive	Left or Right
	630-108	33-9/32"	5	30	2004-96 & Up Chevrolet/GMC 1/2 Ton	Left & Right
	630-109	34-3/4"	5	28	2004-94 GM Astro/Safari w/ABS	Right
	630-110	30-5-16"	5	28	2004-94 GM Astro/Safari w/ABS	Left
	630-111	28-13/16"	5	28	2003-98 GM Blazer, Bravada, Isuzu	Left & Right
	630-112	29"	5	28	1993-91 Chevy/GMC Blazer, S10, Jimmy, Bravada, Syclyone, Typhoon	Right & Left
NEW	630-113	30-1/2"	5	26	1990-82 GM Passenger B & C 7.5 Ratio 4 3/4" Bolt Circle	Left & Right
NEW	630-114	30-3/8"	5	28	1990-77 GM Passenger B&C 8.5 Ratio	Left & Right
NEW	630-115	30-1/4"	5	30	1991-87 GM Camaro, Firebird 9 Bolt Axle Cover; 7-3/4" Gear	Right
NEW	630-116	30-3/8"	5	30	1990-89 GM Caprice 8-1/2" Ring Gear, 4-3/4" Bolt Circle	Left & Right
NEW	630-117	30-7/16"	5	30	1992-91 GM Chevrolet Caprice, Cadillac Fleetwood; 1996-92 Buick Roadmaster Sedan	Left & Right
NEW	630-118	31-13/16"	5	30	1996-91 GM Chevrolet Caprice SW, Oldsmobile Custom Cruiser, Buick Roadmaster SW	Left & Right
NEW	630-119	30-7/16"	5	26	1992-91 GM Chevrolet Caprice Sedan 9-1/2" Brakes; 7-1/2" Ring Gear, 3.08 & 3.23 Ratio	Left & Right
FORD						
NEW	630-200	31-1/16"	5	31	1996-87 Ford 8.8" Diag. Ring Gear; Ford E; 1996-87 F-150 & Bronco; 2/4 Wheel Drive	Right
NEW	630-201	33-3/16"	5	31	1996-87 Ford 8.8" Dia. Ring Gear; Ford F150, Bronco	Left
NEW	630-202	35-5/8"	5	31	1996-87 Ford E150	Left
NEW	630-203	31-1/16"	5	31	1986-83 Ford 8.8" Dia. Ring Gear; F100/150, Bronco, 2 & 4 Wheel Drive	Right
NEW	630-204	33-3/16"	5	31	1991-83 Ford 8.8" Dia. Ring Gear; Bronco, F100 / 150, 2 & 4 Wheel Drive	Left
NEW	630-205	32-1/4"	5	28	2002-98 Ford Crown Victoria or w/ABS	Left & Right
NEW	630-207	31"	5	31	2000-97 Ford Van 1/2 Ton	Right
NEW	630-208	35-11/16"	5	31	2000-97 Ford Van 1/2 Ton	Left
NEW	630-209	30-29/32"	5	28	1989-79 Lincoln Town Car, Mercury Grand Marquis, Ford Crown Victoria	Right & Left
NEW	630-210	31-1/2"	5	28	1997-91 Ford Crown Victoria, Mercury Grand Marquis, Lincoln & Town Car w/o ABS	
NEW	630-211	31-1/2"	5	28	1997-91 Ford Crown Victoria, Mercury Grand Marquis, Lincoln & Town Car w/ ABS	
NEW	630-212	31-3/4"	5	31	2003-97 Ford Truck F150, E150, 7700; 8.8"	Right
NEW	630-213	33-3/8"	5	31	2003-97 Ford F150, E150, 7700 8.8"	Left
JEEP						
NEW	630-300	29-3/4"	5	27	1996-85 Jeep 8.25" Dia. Ring Gear; 1996-92 Cherokee (w/Rear Brake Drum & ABS)	Left & Right
NEW	630-301	30-1/2"	5	27	1998-94 Jeep Grand Cherokee	Right & Left
NEW	630-302	30-1/4"	5	30	1998-96 Jeep Grand Cherokee (Left)	Left
NEW	630-303	30-9/16"	5	27	1991-90 Jeep Cherokee, Comanche, 1990 Wagoneer, 1992-90 Wrangler (Left)	Left
NEW	630-304	29"	5	27	1991-90 Jeep Cherokee, Comanche, 1990 Wagoneer, 1992-90 Wrangler (Right)	Right
NEW	630-305	29-1/4"	5	30	1998-96 Jeep Grand Cherokee (Right)	Right
NEW	630-306	29-1/8"	5	27	1996-94 Jeep Grand Cherokee Dana 35 w/Rear Disc Brakes	Right
CHRYSLER						
NEW	630-400	31-5/8"	5	31	1993-84 Dodge 9-1/4" Dia. Ring Gear; Dodge Ramcharger, Pickups, 4 Wheel Drive	Left or Right

Rear Axle Shaft Kits

Rear Axle Shaft Kit Applications

Make/ Model/Years	Description	Dorman #	Make/ Model/Years	Description	Dorman #
BUICK			CHEVROLET/GMC TRUCK (continued)		
ELECTRA			G20/25/2500 VAN (3/4 TON)		
1984	LH & RH; 7-1/2" Dia Ring Gear; 5" Bolt Circle	630-114	1995-89	LH & RH; 8-1/2" Dia Ring Gear; 30 Spline	630-100
1983-82	LH & RH; 7-1/2" Dia Ring Gear; 4-3/4" Bolt Circle	630-113	1988	LH & RH; 8-1/2" Dia Ring Gear; 30 Spline	630-100
1983-82	LH & RH; 7-1/2" Dia Ring Gear; 5" Bolt Circle	630-114	1999-92	2WD; LH & RH; 8-1/2"; 8-5/8" Dia Ring Gear; 30 Spline	630-106
1981-80	LH & RH; 7-1/2" Dia Ring Gear; 5" Bolt Circle	630-114	1999-92	4WD; LH & RH; 8-1/2"; 8-5/8" Dia Ring Gear; 30 Spline	630-101
ESTATE WAGON			1991-88	LH & RH; 30 Spline	630-104
1990-89	LH & RH; 8-1/2" Dia Ring Gear; 30 Spline	630-118	1988-81	4WD; LH & RH; 8-1/2" Dia Ring Gear; 28 Spline	630-102
1986	LH & RH; 7-1/2" Dia Ring Gear; 4-3/4" Bolt Circle	630-113	1981-70	4WD; LH & RH; 8-3/4"; 8-7/8" Dia Ring Gear; 30 Spline	630-105
1985-81	LH & RH; 7-1/2" Dia Ring Gear; 4-3/4" Bolt Circle	630-113	K10/15/1500 4WD PICKUP (1/2 TON)		
1985-81	LH & RH; 7-1/2" Dia Ring Gear; 5" Bolt Circle	630-114	1999-89	LH & RH; 8-1/2"; 8-5/8" Dia Ring Gear; 30 Spline	630-101
1980-77	LH & RH; 7-1/2" Dia Ring Gear; 4-3/4" Bolt Circle	630-113	1988	LH & RH; 8-1/2"; 8-5/8" Dia Ring Gear; 30 Spline	630-101
LESABRE			1986-81	LH & RH; 8-1/2" Dia Ring Gear; 28 Spline	630-102
1985-81	LH & RH; 7-1/2" Dia Ring Gear; 4-3/4" Bolt Circle	630-113	1981-70	LH & RH; 8-3/4"; 8-7/8" Dia Ring Gear; 30 Spline	630-105
1985-81	LH & RH; 7-1/2" Dia Ring Gear; 5" Bolt Circle	630-114	S10 BLAZER, S15 JIMMY, S15 TYPHOON		
1980-77	LH & RH; 7-1/2" Dia Ring Gear; 4-3/4" Bolt Circle	630-113	2005-03	2WD; LH & RH; 7-5/8" Dia Ring Gear; w/Positraction; 29 1/2" Lg	630-111
RIVIERA			2005-03	4WD; LH & RH; 7-5/8" Dia Ring Gear; 29 1/2" Lg	630-111
1978-77	LH & RH; 7-1/2" Dia Ring Gear; 4-3/4" Bolt Circle	630-113	2002-98	4WD; LH & RH; 7-5/8" Dia Ring Gear; 29 1/2" Lg	630-111
ROADMASTER			1997-96	4WD; LH & RH; 7-5/8" Dia Ring Gear; Exc. All Wheel Drive; 28 Spline	630-103
1996-91	LH & RH; 8-1/2"; 8-5/8" Dia Ring Gear; 30 Spline; Wagon	630-118	1997	4WD; LH & RH; 7-5/8" Dia Ring Gear; All Wheel Drive	630-111
1996-91	LH & RH; 8-1/2"; 8-5/8" Dia Ring Gear; Exc. Wagon	630-117	1995	4WD; LH & RH; 7-5/8" Dia Ring Gear; Exc. All Wheel Drive; 28 Spline	630-103
CADILLAC			1994	4WD; LH & RH; 7-5/8" Dia Ring Gear; 28 Spline	630-103
DEVILLE			1993-91	4WD; LH & RH; 7-5/8" Dia Ring Gear; 28 Spline	630-103
1984-82	LH & RH; 7-1/2" Dia Ring Gear; 5" Bolt Circle	630-114	1993-91	4WD; LH & RH; 7-5/8" Dia Ring Gear; 4 Sensor System	630-112
ESCALADE			1990	4WD; LH & RH; 7-5/8" Dia Ring Gear; 28 Spline	630-103
1999	2WD; LH & RH; 8-1/2"; 8-5/8" Dia Ring Gear; 30 Spline	630-106	1989-88	4WD; LH & RH; 7-5/8" Dia Ring Gear; 28 Spline	630-103
1999	4WD; LH & RH; 8-1/2"; 8-5/8" Dia Ring Gear; 30 Spline	630-101	S10 PICKUP, S15 PICKUP, SONOMA, S15 SYCLONE		
FLEETWOOD			2005-03	4WD; LH & RH; 7-5/8" Dia Ring Gear; 29 1/2" Lg	630-111
1992-91	LH & RH; 8-1/2"; 8-5/8" Dia Ring Gear	630-117	2002-98	4WD; LH & RH; 7-5/8" Dia Ring Gear; 29 1/2" Lg	630-111
1990-89	LH & RH; 7-1/2" Dia Ring Gear; 5" Bolt Circle	630-114	1997-90	4WD; LH & RH; 7-5/8" Dia Ring Gear; 28 Spline	630-103
1990-89	LH & RH; 8-1/2"; 8-5/8" Dia Ring Gear; 3.08R, 3.42R; 30 Spline	630-115	1991	4WD; LH & RH; 7-5/8" Dia Ring Gear; 4 Sensor System	630-112
1988-82	LH & RH; 7-1/2" Dia Ring Gear; 5" Bolt Circle	630-114	1989-88	4WD; LH & RH; 7-5/8" Dia Ring Gear; 28 Spline	630-103
CHEVROLET			SAFARI		
CAPRICE			2002-93	LH Rear Axle	630-110
1996-93	LH & RH; 8-1/2"; 8-5/8" Dia Ring Gear; 2.73R, 2.93R, 3.23R; w/HD Brakes; Exc. Wagon	630-117	2002-93	RH Rear Axle	630-109
1996-93	LH & RH; 8-1/2"; 8-5/8" Dia Ring Gear; 30 Spline; Wagon	630-118	1992	LH Rear Axle, 2WD, w/Rear Wheel ABS(JA4)	630-110
1992-91	LH & RH; 7-1/2" Dia Ring Gear	630-119	1992	RH Rear Axle, 2WD, w/Rear Wheel ABS(JA4)	630-109
1992-91	LH & RH; 8-1/2"; 8-5/8" Dia Ring Gear; 30 Spline; Wagon	630-118	1992	RH Rear Axle, 4WD, wo/Speed Sensor Ring	630-109
1992-91	LH & RH; 8-1/2"; 8-5/8" Dia Ring Gear; Exc. Wagon	630-117	1991-90	LH Rear Axle, w/Rear Wheel ABS(JA4), 2WD	630-110
1990-88	LH & RH; 7-1/2" Dia Ring Gear; 4-3/4" Bolt Circle	630-113	1991-90	RH Rear Axle, w/Rear Wheel ABS(JA4)	630-109
1990-88	LH & RH; 8-1/2" Dia Ring Gear; 2.73R, 3.08R; Exc. Limited Slip; 30 Spline; Exc. Wagon	630-116	SAVANA 1500 VAN (1/2 TON)		
1990-88	LH & RH; 8-1/2" Dia Ring Gear; 3.08R, 3.42R; Limited Slip; 30 Spline; Exc. Wagon	630-115	2002-96	LH & RH; 10 Bolt	630-108
1990-88	LH & RH; 8-1/2"; 8-5/8" Dia Ring Gear; 30 Spline; Wagon	630-118	SUBURBAN		
1987-86	LH & RH; 7-1/2" Dia Ring Gear; 4-3/4" Bolt Circle	630-113	1999-95	1/2 Ton; 2WD; LH & RH; 8-1/2"; 8-5/8" Dia Ring Gear; 30 Spline	630-106
1985-83	LH & RH; 7-1/2" Dia Ring Gear; 4-3/4" Bolt Circle	630-113	1999-95	1/2 Ton; 4WD; LH & RH; 8-1/2"; 8-5/8" Dia Ring Gear; 30 Spline	630-101
1985-83	LH & RH; 7-1/2" Dia Ring Gear; 5" Bolt Circle	630-114	1994-92	1/2 Ton; 2WD; LH & RH; 8-1/2"; 8-5/8" Dia Ring Gear; 30 Spline	630-106
1982-77	LH & RH; 7-1/2" Dia Ring Gear; 4-3/4" Bolt Circle	630-113	1994-92	1/2 Ton; 4WD; LH & RH; 8-1/2"; 8-5/8" Dia Ring Gear; 30 Spline	630-101
IMPALA			1991-87	1/2 Ton; 2WD; LH & RH; 30 Spline	630-107
1985-83	LH & RH; 7-1/2" Dia Ring Gear; 4-3/4" Bolt Circle	630-113	1991-87	1/2 Ton; 4WD; LH & RH; 30 Spline	630-104
1985-83	LH & RH; 7-1/2" Dia Ring Gear; 5" Bolt Circle	630-114	1986-82	1/2 Ton; 4WD; LH & RH; 8-1/2" Dia Ring Gear; 28 Spline	630-102
1982-77	LH & RH; 7-1/2" Dia Ring Gear; 4-3/4" Bolt Circle	630-113	1981-78	1/2 Ton; 4WD; LH & RH; 8-3/4"; 8-7/8" Dia Ring Gear; 30 Spline	630-105
IMPALA SS			1977-73	1/2 Ton; 4WD; LH & RH; 8-3/4"; 8-7/8" Dia Ring Gear; 30 Spline	630-105
1996-94	LH & RH; 8-1/2"; 8-5/8" Dia Ring Gear; 2.93R, 3.23R; w/HD Brakes	630-117	1972-70	1/2 Ton; 4WD; LH & RH; 8-3/4"; 8-7/8" Dia Ring Gear; 30 Spline	630-105
CHEVROLET/GMC TRUCK			V10/1500 4WD PICKUP (1/2 TON)		
ASTRO			1987	LH & RH; 8-1/2" Dia Ring Gear; 28 Spline	630-102
2002-93	LH Rear Axle	630-110	DODGE TRUCK		
2002-93	RH Rear Axle	630-109	D100/150 2WD PICKUP (1/2 TON)		
1992	LH Rear Axle, 2WD, w/Rear Wheel ABS(JA4)	630-110	1993-85	LH & RH; 9-1/4" Dia Ring Gear; 31 Spline	630-400
1992	RH Rear Axle, 2WD, w/Rear Wheel ABS(JA4)	630-109	RAMCHARGER		
1992	RH Rear Axle, 4WD, wo/Speed Sensor Ring	630-109	1993-85	LH & RH; 9-1/4" Dia Ring Gear; 31 Spline	630-400
1991-90	LH Rear Axle, w/Rear Wheel ABS(JA4), 2WD	630-110	1984	4WD; LH & RH; From 4/2/84; 9-1/4" Dia Ring Gear; 31 Spline	630-400
1991-90	RH Rear Axle, w/Rear Wheel ABS(JA4)	630-109	W100/150 4WD PICKUP (1/2 TON)		
BLAZER, TAHOE			1993-85	LH & RH; 9-1/4" Dia Ring Gear; 31 Spline	630-400
1999-92	2WD; LH & RH; 8-1/2"; 8-5/8" Dia Ring Gear; 30 Spline	630-106	1984	LH & RH; From 4/2/84; 9-1/4" Dia Ring Gear; 31 Spline	630-400
1999-92	4WD; LH & RH; 8-1/2"; 8-5/8" Dia Ring Gear; 30 Spline	630-101	FORD		
1991-88	LH & RH; 30 Spline	630-104	COUNTRY SQUIRE		
1987-82	4WD; LH & RH; 8-1/2" Dia Ring Gear; 28 Spline	630-102	1991	LH & RH; w/ABS	630-211
1981-78	4WD; LH & RH; 8-1/2" Dia Ring Gear; 28 Spline	630-102	1991	LH & RH; wo/ABS	630-210
1981-78	4WD; LH & RH; 8-3/4"; 8-7/8" Dia Ring Gear; 30 Spline	630-105	1989-79	LH & RH	630-209
1977-70	4WD; LH & RH; 8-3/4"; 8-7/8" Dia Ring Gear; 30 Spline	630-105	Fuel Sending Units		
C10/15/1500 2WD PICKUP (1/2 TON)			pg. 155-176		
1999-88	LH & RH; 8-1/2"; 8-5/8" Dia Ring Gear; 30 Spline	630-106	Fuel Tanks		
EXPRESS 1500 VAN (1/2 TON)			pg. 177-228		
2002-96	LH & RH; 10 Bolt	630-108	Harmonic Balancers		
G10/15/1500 VAN (1/2 TON)			pg. 229-254		
1995-89	LH & RH; 8-1/2" Dia Ring Gear; 30 Spline	630-100	Heater Hose Assemblies		
1988	LH & RH; 8-1/2" Dia Ring Gear; 30 Spline	630-100	pg. 255-256		
			Hydraulic Clutch Lines		
			pg. 257-260		

Rear Axle Shaft Kit Applications

Make/ Model/Years	Description	Dorman #
FORD (continued)		
CROWN VICTORIA		
2002-01	LH & RH; w/ABS	630-205
2000-98	LH & RH; w/ABS	630-205
1997-91	LH & RH; w/ABS	630-211
1997-91	LH & RH; wo/ABS	630-210
1989-83	LH & RH	630-209
LTD		
1982-79	LH & RH	630-209
FORD TRUCK		
BRONCO		
1996-87	LH; 31 Spline	630-201
1996-87	RH; 31 Spline	630-200
1986-83	LH; 31 Spline	630-204
1986-83	RH; 31 Spline	630-203
BRONCO II		
1990-89	LH; 31 Spline	630-201
E-150 ECONOLINE (1/2 TON)		
2000-97	LH; w/8.8" Dia Ring Gear; 31 Spline	630-208
2000-97	RH; w/8.8" Dia Ring Gear; 31 Spline	630-207
1996-87	LH; 31 Spline	630-202
1996-87	RH; 31 Spline	630-200
EXPEDITION		
2000-97	LH; w/8.8" Dia Ring Gear (WDR Non-Locking Rear); Tag No. 824A, 826A, 828A, 852A, 852B, 854A, 854B, 862A, 862B, 862C	630-213
2000-97	RH; w/8.8" Dia Ring Gear (WDR Non-Locking Rear); Tag No. 824A, 826A, 828A, 852A, 852B, 854A, 854B, 862A, 862B, 862C	630-212
1999-97	LH; w/8.8" Dia Ring Gear (WFL Locking Rear); Tag No. 829A, 829C, 869A, 869B, 869C, 871A, 871B	630-213
1999-97	RH; w/8.8" Dia Ring Gear (WFL Locking Rear); Tag No. 829A, 829C, 869A, 869B, 869C, 871A, 871B	630-212
F-100/150 PICKUP (1/2 TON)		
2000-97	LH; w/8.8" Dia Ring Gear; (WDR Non-Locking Rear); Tag No. 824A, 826A, 828A, 852A, 852B, 854A, 854B, 862A, 862B, 862C	630-213
2000-97	RH; w/8.8" Dia Ring Gear; (WDR Non-Locking Rear); Tag No. 824A, 826A, 828A, 852A, 852B, 854A, 854B, 862A, 862B, 862C	630-212
1999-97	LH; w/8.8" Dia Ring Gear; (WFL Locking Rear); Tag No. 829A, 829C, 869A, 869B, 869C, 871A, 871B	630-213
1999-97	RH; w/8.8" Dia Ring Gear; (WFL Locking Rear); Tag No. 829A, 829C, 869A, 869B, 869C, 871A, 871B	630-212
1996-92	LH; 31 Spline	630-201
1996-92	RH; 31 Spline	630-200
1991-83	LH; 31 Spline	630-204
1991-83	RH; 31 Spline	630-203
RANGER		
1992-89	LH; 31 Spline	630-201
1992-89	RH; 31 Spline	630-200
JEEP		
CHEROKEE		
2001-92	RH; w/Dana 35 Axle	630-300
1991-90	LH; w/Dana 35 Axle	630-303
1991-90	RH; w/Dana 35 Axle	630-304
CJ SERIES (CJ5, CJ7)		
1986-82	LH; CJ5	630-303
1986-82	LH; CJ7	630-301
1981-76	LH; wo/Quadra Trac	630-303
COMANCHE		
1991-90	LH; w/Dana 35 Axle	630-303
1991-90	RH; w/Dana 35 Axle	630-304
GRAND CHEROKEE		
1998-94	LH; w/Dana 44 Axle	630-302
1998-94	RH; w/Dana 44 Axle	630-305
1998-93	LH; w/Dana 35 Axle; w/Rear Disc Brakes	630-301
1998-93	RH; w/Dana 35 Axle; w/Rear Disc Brakes	630-306
SCRAMBLER		
1985-82	LH	630-301
1981	LH; wo/Quadra Trac	630-303

Make/ Model/Years	Description	Dorman #
JEEP (continued)		
WAGONEER		
1990	LH; w/Dana 35 Axle	630-303
1990	RH; w/Dana 35 Axle	630-304
WRANGLER		
1992-91	LH; w/Dana 35 Axle	630-303
1992-91	RH; w/Dana 35 Axle	630-304
LINCOLN		
CONTINENTAL		
1981-80	LH & RH	630-209
MARK VI		
1983-80	LH & RH	630-209
TOWN CAR		
2002-01	LH & RH; w/ABS	630-205
2000-98	LH & RH; w/ABS	630-205
1997-91	LH & RH; w/ABS; Exc. Limo	630-211
1997-91	LH & RH; wo/ABS; Exc. Limo	630-210
1989-82	LH & RH	630-209
MERCURY		
COLONY PARK		
1991	LH & RH; w/ABS	630-211
1991	LH & RH; wo/ABS	630-210
1989-79	LH & RH	630-209
GRAND MARQUIS		
2002-01	LH & RH; w/ABS	630-205
2000-98	LH & RH; w/ABS	630-205
1997-91	LH & RH; w/ABS	630-211
1997-91	LH & RH; wo/ABS	630-210
1989-79	LH & RH	630-209
MARQUIS		
1982-79	LH & RH	630-209
OLDSMOBILE		
98		
1984	LH & RH; 7-1/2" Dia Ring Gear; 5" Bolt Circle	630-114
1983-82	LH & RH; 7-1/2" Dia Ring Gear; 4-3/4" Bolt Circle	630-113
1983-82	LH & RH; 7-1/2" Dia Ring Gear; 5" Bolt Circle	630-114
1981-80	LH & RH; 7-1/2" Dia Ring Gear; 5" Bolt Circle	630-114
BRAVADA		
2001-97	4WD; LH & RH; 7-5/8" Dia Ring Gear	630-111
1994-91	4WD; LH & RH; 7-5/8" Dia Ring Gear; 28 Spline	630-103
1993-91	4WD; LH & RH; 7-5/8" Dia Ring Gear; 4 Sensor System	630-112
CUSTOM CRUISER		
1992-89	LH & RH; 8-1/2"; 8-5/8" Dia Ring Gear; 30 Spline	630-118
1986-84	LH & RH; 7-1/2" Dia Ring Gear; 4-3/4" Bolt Circle	630-113
1983-82	LH & RH; 7-1/2" Dia Ring Gear; 4-3/4" Bolt Circle	630-113
1983-82	LH & RH; 7-1/2" Dia Ring Gear; 5" Bolt Circle	630-114
1981-77	LH & RH; 7-1/2" Dia Ring Gear; 4-3/4" Bolt Circle	630-113
DELTA 88		
1985-84	LH & RH; 7-1/2" Dia Ring Gear; 4-3/4" Bolt Circle	630-113
1983-82	LH & RH; 7-1/2" Dia Ring Gear; 4-3/4" Bolt Circle	630-113
1983-82	LH & RH; 7-1/2" Dia Ring Gear; 5" Bolt Circle	630-114
1981-77	LH & RH; 7-1/2" Dia Ring Gear; 4-3/4" Bolt Circle	630-113
PONTIAC		
BONNEVILLE		
1981	LH & RH; 7-1/2" Dia Ring Gear; 4-3/4" Bolt Circle	630-113
1980	LH & RH; 7-1/2" Dia Ring Gear; 4-3/4" Bolt Circle	630-113
1980	LH & RH; 7-1/2" Dia Ring Gear; 5" Bolt Circle	630-114
1979-77	LH & RH; 7-1/2" Dia Ring Gear; 4-3/4" Bolt Circle	630-113
CATALINA		
1981	LH & RH; 7-1/2" Dia Ring Gear; 4-3/4" Bolt Circle	630-113
1980	LH & RH; 7-1/2" Dia Ring Gear; 4-3/4" Bolt Circle	630-113
1980	LH & RH; 7-1/2" Dia Ring Gear; 5" Bolt Circle	630-114
1979-77	LH & RH; 7-1/2" Dia Ring Gear; 4-3/4" Bolt Circle	630-113
GRAND SAFARI		
1978-77	LH & RH; 7-1/2" Dia Ring Gear; 4-3/4" Bolt Circle	630-113
PARISIENNE		
1986-83	LH & RH; 7-1/2" Dia Ring Gear; 4-3/4" Bolt Circle	630-113
SAFARI		
1989	LH & RH; 8-1/2"; 8-5/8" Dia Ring Gear; 30 Spline	630-118